

Name ..... 000279359 ..... Index Number ..... / .....

121/2  
**MATHEMATICS ALT. A**  
**Paper 2**  
**Oct./Nov. 2015**  
 2½ hours

Candidate's Signature .....

Date .....



**THE KENYA NATIONAL EXAMINATIONS COUNCIL**  
**Kenya Certificate of Secondary Education**  
**MATHEMATICS ALT. A**  
**Paper 2**  
 2½ hours

**00111511**

**Instructions to candidates**

- (a) Write your name and index number in the spaces provided above.
- (b) Sign and write the date of examination in the spaces provided above.
- (c) This paper consists of **TWO** sections: **Section I** and **Section II**.
- (d) Answer **ALL** the questions in **Section I** and only **five** questions from **Section II**.
- (e) **Show all the steps in your calculations, giving your answers at each stage in the spaces provided below each question.**
- (f) Marks may be given for correct working even if the answer is wrong.
- (g) **Non-programmable** silent electronic calculators **and** KNEC Mathematical tables may be used, except where stated otherwise.
- (h) **This paper consists of 19 printed pages.**
- (i) **Candidates should check the question paper to ascertain that all the pages are printed as indicated and that no questions are missing.**
- (j) **Candidates should answer the questions in English.**

**For Examiner's Use Only**

**Section I**

1	2	3	4	5	6	7	8	9	10	11	12	13	14	15	16	Total

**Section II**

17	18	19	20	21	22	23	24	Total

**Grand Total**

--



**SECTION I** (50 marks)

Answer **all** the questions in this section in the spaces provided.

- 1** The length and width of a rectangular piece of paper were measured as 60 cm and 12 cm respectively. Determine the relative error in the calculation of its area. (4 marks)

- 2** Simplify  $\frac{\sqrt{11}}{\sqrt{11}-\sqrt{7}}$  (2 marks)

- 3** An arc 11 cm long, subtends an angle of  $70^\circ$  at the centre of a circle. Calculate the length, correct to one decimal place, of a chord that subtends an angle of  $90^\circ$  at the centre of the same circle. (4 marks)

- 4 In the figure below, O is the centre of the circle. A, B, C and D are points on the circumference of the circle. Line AB is parallel to line DC and angle  $ADC = 55^\circ$ .

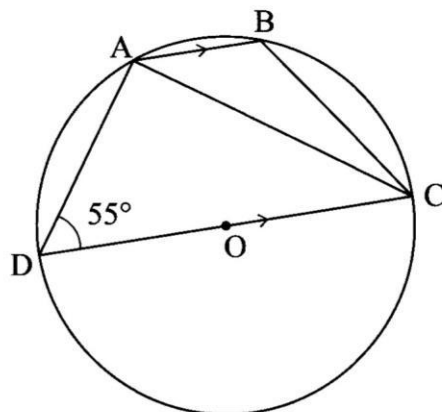

Determine the size of angle ACB.

(3 marks)

- 5 Eleven people can complete  $\frac{3}{5}$  of a certain job in 24 hours. Determine the time in hours, correct to 2 decimal places, that 7 people working at the same rate can take to complete the remaining job. (3 marks)

- 6 The length and width of a rectangular signboard are  $(3x + 12)$  cm and  $(x - 4)$  cm respectively. If the diagonal of the signboard is 200 cm, determine its area. (4 marks)

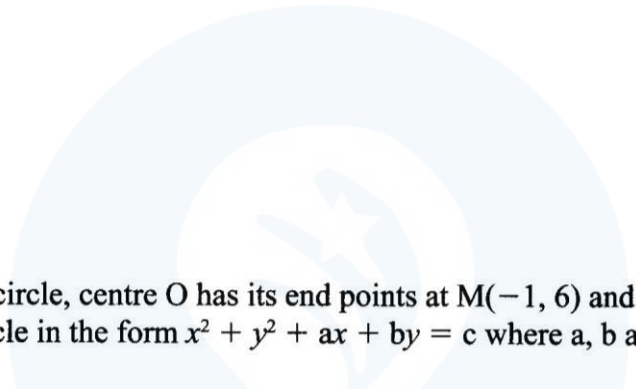
- 7 Find the value of  $x$  given that  $\log(x - 1) + 2 = \log(3x + 2) + \log 25$ . (3 marks)
- 8 Use the expansion of  $(x - y)^5$  to evaluate  $(9.8)^5$  correct to 4 decimal places. (3 marks)
- 9 The diameter of a circle, centre O has its end points at  $M(-1, 6)$  and  $N(5, -2)$ . Find the equation of the circle in the form  $x^2 + y^2 + ax + by = c$  where  $a$ ,  $b$  and  $c$  are constants. (4 marks)
- 

- 10 Below is a line AB and a point X. Determine the locus of a point P equidistant from points A and B and 4 cm from X. (3 marks)



- 11 In a nomination for a committee, two people were to be selected at random from a group of 3 men and 5 women. Find the probability that a man and a woman were selected. (2 marks)

- 12 A school decided to buy at least 32 bags of maize and beans. The number of bags of maize were to be more than 20 and the number of bags of beans were to be at least 6. A bag of maize costs Ksh 2500 and a bag of beans costs Ksh 3500. The school had Ksh 100 000 to purchase the maize and beans. Write down all the inequalities that satisfy the above information. (4 marks)

- 13 Evaluate  $\int_2^4 x^2 + 2x - 15 dx$ . (3 marks)

- 14 The positions of two points P and Q, on the surface of the earth are P(45°N, 36°E) and Q(45°N, 71°E). Calculate the distance, in nautical miles, between P and Q, correct to 1 decimal place. (3 marks)

15 Solve the equation  $\sin\left(\frac{1}{2}x - 30^\circ\right) = \cos x$  for  $0 < x < 90^\circ$ . (2 marks)

16 The position vectors of points P, Q and R are  $\mathbf{OP} = \begin{pmatrix} -3 \\ 6 \end{pmatrix}$ ,  $\mathbf{OQ} = \begin{pmatrix} 2 \\ 1 \end{pmatrix}$ ,  $\mathbf{OR} = \begin{pmatrix} 4 \\ -1 \end{pmatrix}$ . Show that P, Q and R are collinear. (3 marks)



**SECTION II (50 marks)**

*Answer any five questions from this section in the spaces provided.*

**17** In a retail shop, the marked price of a cooker was Ksh 36 000. Wanandi bought the cooker on hire purchase terms. She paid Ksh 6400 as deposit followed by 20 equal monthly instalments of Ksh 1750.

(a) Calculate:

(i) the total amount of money she paid for the cooker. (2 marks)

(ii) the extra amount of money she paid above the marked price. (1 mark)

(b) The total amount of money paid on hire purchase terms was calculated at a compound interest rate on the marked price for 20 months. Determine the rate, per annum, of the compound interest correct to 1 decimal place. (4 marks)



- (c) Kaloki borrowed Ksh 36 000 from a financial institution to purchase a similar cooker. The financial institution charged a compound interest rate equal to the rate in (b) above for 24 months. Calculate the interest Kaloki paid correct to the nearest shilling. (3 marks)



**18** Mute cycled to raise funds for a charitable organisation. On the first day, he cycled 40 km. For the first 10 days, he cycled 3 km less on each subsequent day. Thereafter, he cycled 2 km less on each subsequent day.

(a) Calculate:

(i) the distance cycled on the 10th day; (2 marks)

(ii) the distance cycled on the 16th day. (3 marks)

(b) If Mute raised Ksh 200 per km, calculate the amount of money collected. (5 marks)

19 The equation of a curve is given by  $y = 1 + 3 \sin x$ .

(a) Complete the table below for  $y = 1 + 3 \sin x$  correct to 1 decimal place. (2 marks)

$x^\circ$	0	30	60	90	120	150	180	210	240	270	300	330	360
$y = 1 + 3 \sin x$	1		3.6				1	-0.5			-1.6		

(b) (i) On the grid provided, draw the graph of  $y = 1 + 3 \sin x$  for  $0 \leq x \leq 360^\circ$ . (3 marks)

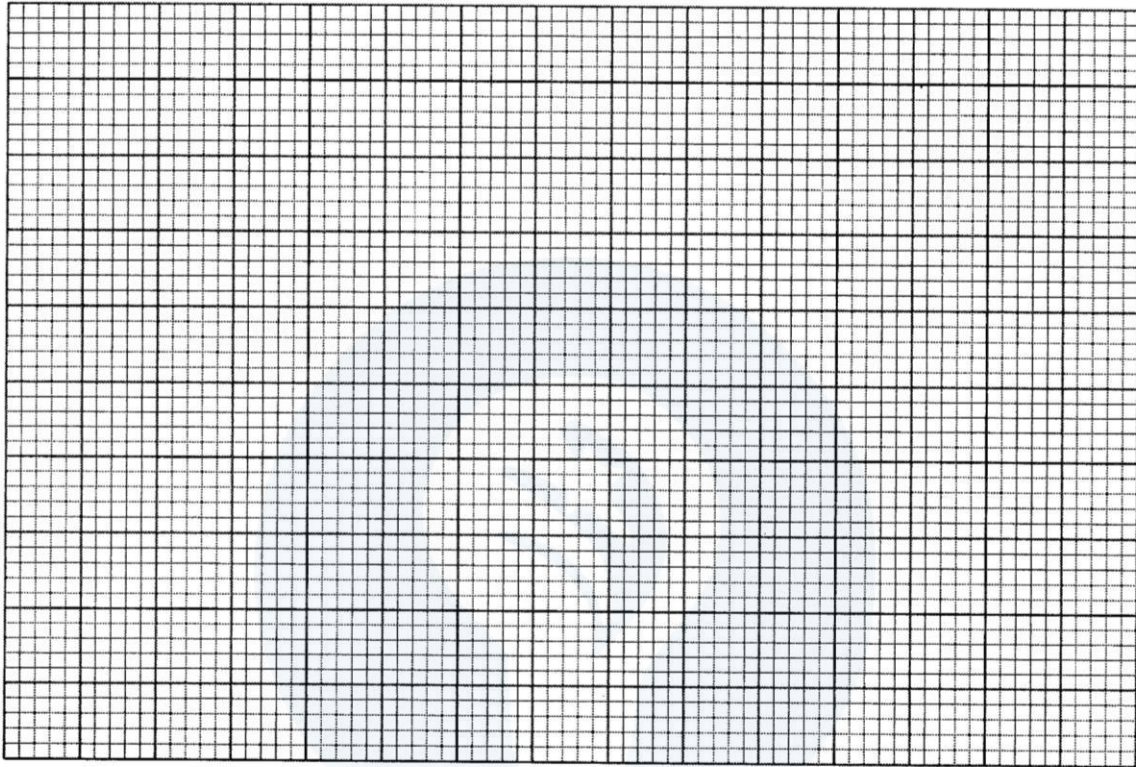

(ii) State the amplitude of the curve  $y = 1 + 3 \sin x$ . (1 mark)

(c) On the same grid draw the graph of  $y = \tan x$  for  $90^\circ \leq x \leq 270^\circ$ . (3 marks)

(d) Use the graphs to solve the equation  $1 + 3 \sin x = \tan x$  for  $90^\circ \leq x \leq 270^\circ$ . (1 mark)

- 20 The figure below represents a cuboid EFGHJKLM in which  $EF = 40$  cm,  $FG = 9$  cm and  $GM = 30$  cm. N is the midpoint of LM.

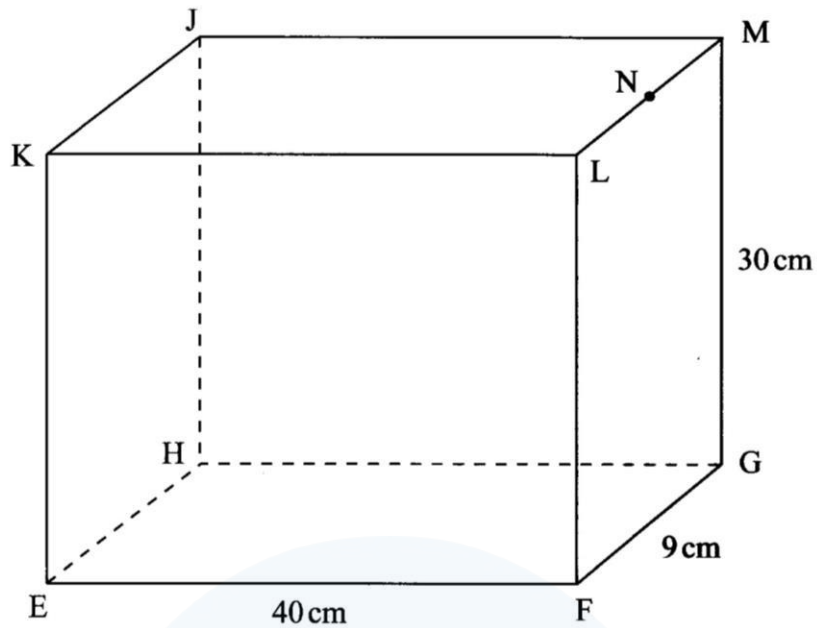

Calculate correct to 4 significant figures:

- (a) the length of GL; (1 mark)
- (b) the length of FJ; (2 marks)
- (c) the angle between EM and the plane EFGH; (3 marks)

(d) the angle between the planes EFGH and ENH; (2 marks)

(e) the angle between the lines EH and GL. (2 marks)



**21** A quantity  $P$  varies partly as the square of  $m$  and partly as  $n$ . When  $P = 3.8$ ,  $m = 2$  and  $n = -3$ .  
When  $P = -0.2$ ,  $m = 3$  and  $n = 2$ .

(a) Find:

(i) the equation that connects  $P$ ,  $m$  and  $n$ ; (4 marks)

(ii) the value of  $P$  when  $m = 10$  and  $n = 4$ . (1 mark)

(b) Express  $m$  in terms of  $P$  and  $n$ . (2 marks)

(c) If  $P$  and  $n$  are each increased by 10%, find the percentage increase in  $m$  correct to 2 decimal places. (3 marks)

- 22 A particle was moving along a straight line. The acceleration of the particle after  $t$  seconds was given by  $(9 - 3t) \text{ ms}^{-2}$ . The initial velocity of the particle was  $7 \text{ ms}^{-1}$ .

Find:

- (a) the velocity ( $v$ ) of the particle at any given time ( $t$ ); (4 marks)

- (b) the maximum velocity of the particle; (3 marks)

- (c) the distance covered by the particle by the time it attained maximum velocity. (3 marks)



- 23 The marks scored by 40 students in a mathematics test were as shown in the table below.

Marks	48–52	53–57	58–62	63–67	68–72	73–77
Number of students	3	4	10	12	8	3

- (a) Find the lower class boundary of the modal class. (1 mark)
- (b) Using an assumed mean of 64, calculate the mean mark. (3 marks)
- (c) (i) On the grid provided, draw the cumulative frequency curve for the data. (3 marks)

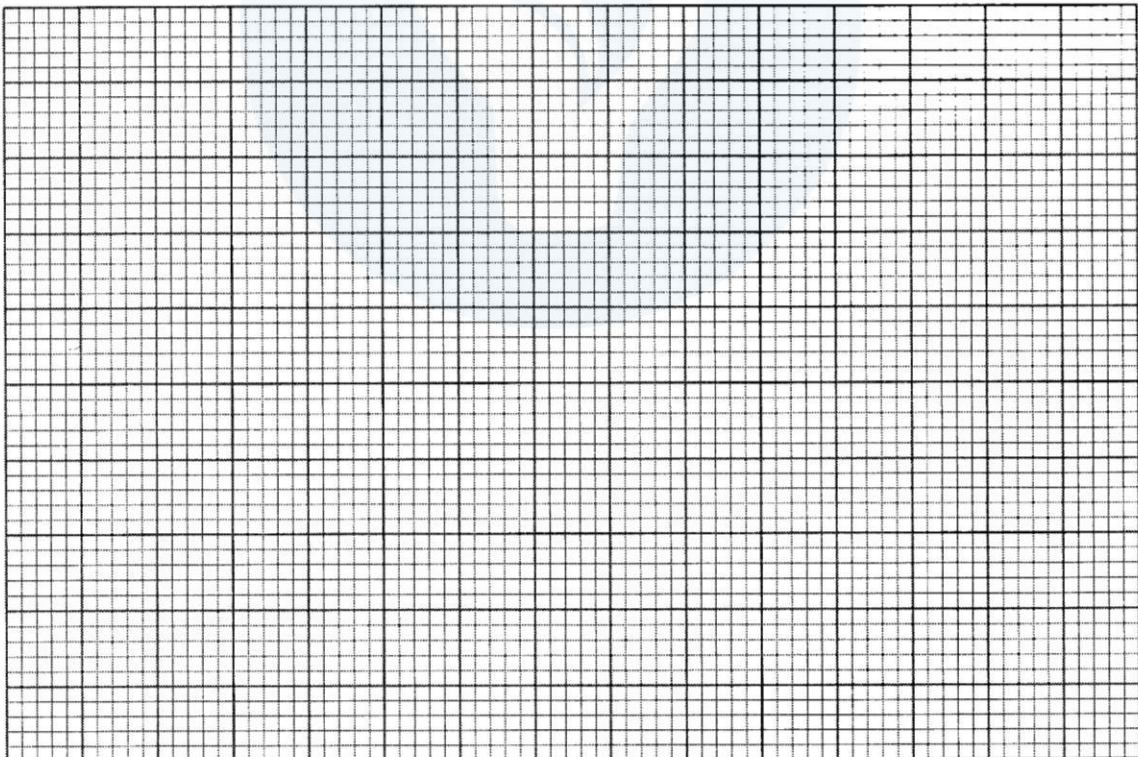

(ii) use the graph to estimate the semi-interquartile range

(3 marks)



- 24 A quadrilateral with vertices at  $K(1, 1)$ ,  $L(4, 1)$ ,  $M(2, 3)$  and  $N(1, 3)$  is transformed by a matrix  $T = \begin{pmatrix} 1 & 3 \\ 0 & 1 \end{pmatrix}$  to a quadrilateral  $K'L'M'N'$
- (a) Determine the coordinates of the image. (3 marks)

- (b) On the grid provided draw the object and the image. (2 marks)

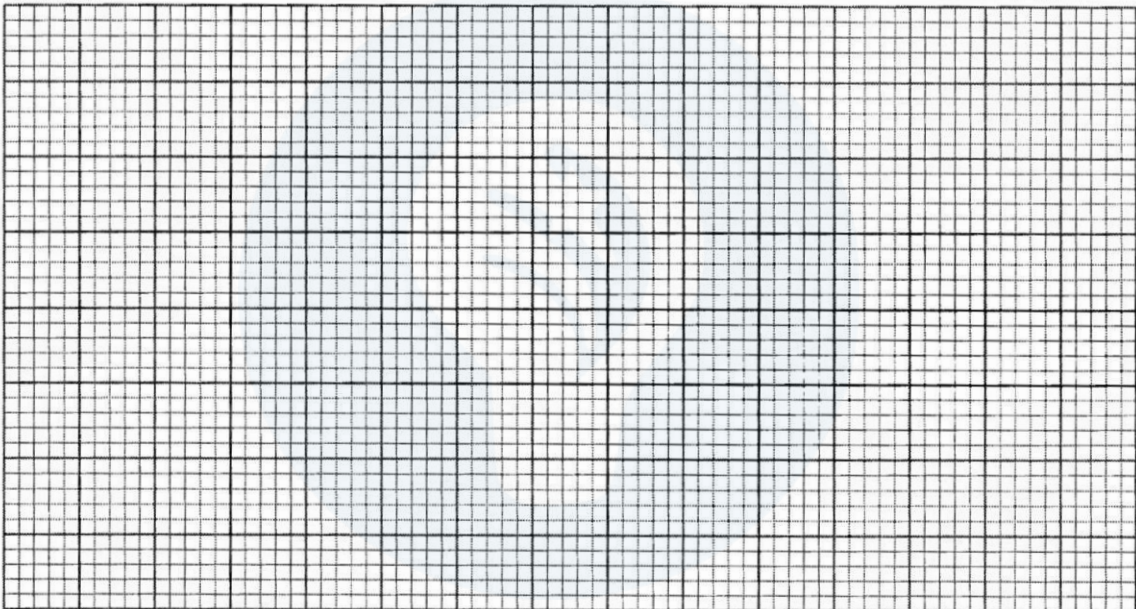

- (c) (i) Describe fully the transformation which maps  $KLMN$  onto  $K'L'M'N'$ . (2 marks)

(ii) Determine the area of the image. (1 mark)

(d) Find a matrix which maps  $K'L'M'N'$  onto  $KLMN$ . (2 marks)

